



FEATURES

- ▶ Lowest Rds(on)
- ▶ Current capability (300A)
- ▶ Very low package parasitics and inductances
- ▶ Paralleling & cooling reduction
- ▶ System cost reduction
- ▶ Compact design

NEW DEVELOPMENTS

- ▶ Side by side dual die capability
- ▶ Dual exposed pad for better thermal performance
- ▶ Thin wafer dicing with narrow saw streets
- ▶ Larger/higher-density leadframe strips
- ▶ Environmentally-friendly Pb-free solder paste
- ▶ Al wire interconnect

TOLL

TOLL (TO-Leadless) is a highly efficient space-saving package designed for currents up to 300A in automotive applications.

- ▶ This package features
 - ▷ Very low parasitics and inductances resulting in world-class package level Rds(on)
 - ▷ Outstanding EMI behavior and excellent thermal performance
 - ▷ Space reduction with a layout 30% smaller & 50% thinner than the 7 ld DPAK package
 - ▷ Package is offered with wettable flanks and is well suited to the automotive market
 - ▷ This package is a registered JEDEC package outline

Applications

TOLL is suitable for high-power applications, designed for low on-resistance and high-speed-switching MOSFETs.

- ▶ Automotive
- ▶ Telecom
- ▶ Point of Load (POL)
- ▶ Light Electric Vehicles (LEV)
- ▶ Battery management

Reliability Qualification

- ▶ All reliability test includes JSTD-020 moisture pre-conditioning except high temperature storage
- ▶ Moisture sensitivity characterization: JEDEC level 1 85°C/85% RH, 168 hours, IR reflow 260°C 3x
- ▶ uHAST: 130°C/85% RH, no bias, 96 hours
- ▶ Temperature cycle: -65~150°C, 500 cycles
- ▶ High temperature storage: 150°C for 1000 hours

Test Services

Amkor offers full turnkey business for all power discrete products, with the capability to test various types of power devices including MOSFETs, bipolar transistors, IGBTs, diodes and regulator ICs/intelligent power devices.

- ▶ Amkor power discrete test capability
 - ▷ Static test (DC)
 - ▷ Dynamic test (AC, switching/trr, capacitance/Rg)
 - ▷ Destruction test (inductive load/VSUS)
 - ▷ Thermal resistance (ΔV_{DS} , ΔmV , etc.)
- ▶ Program generation/conversion
- ▶ Failure analysis
- ▶ Available test/handling technology
- ▶ Integrated marking, vision inspection and tape & reel services

TOLL

Standard Materials

- ▶ Leadframe: Bare copper
- ▶ Die attach: Solder paste
- ▶ Interconnect (3 options)
 - ▷ Copper clip
 - ▷ Cu Clip + Cu wire
 - ▷ Multiple Cu wires
 - ▷ Multiple Al wires (under development)
- ▶ Mold compound: Halogen-free

Shipping

- ▶ Tape and reel packing
 - ▷ 1800 pcs per reel
 - ▷ Tape width: 24 mm
 - ▷ Reel Φ = 330 mm
- ▶ Barcode packing label
- ▶ Drop ship

Package Outline Drawing

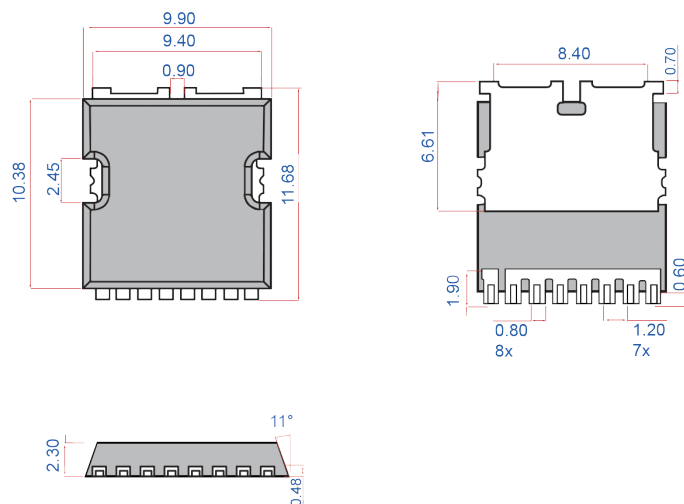

Cross Sections

Copper Clip

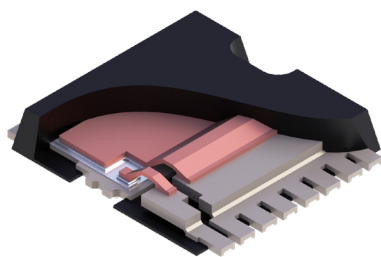

Multiple Copper Wires

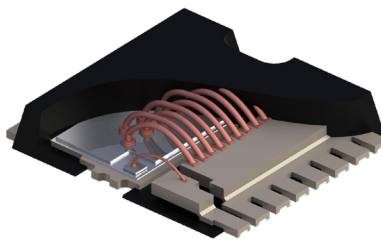

Copper Clip and Wire

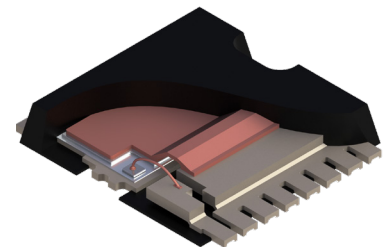

Visit amkor.com or email sales@amkor.com for more information.

With respect to the information in this document, Amkor makes no guarantee or warranty of its accuracy or that the use of such information will not infringe upon the intellectual rights of third parties. Amkor shall not be responsible for any loss or damage of whatever nature resulting from the use of, or reliance upon it and no patent or other license is implied hereby. This document does not in any way extend or modify Amkor's warranty on any product beyond that set forth in its standard terms and conditions of sale. Amkor reserves the right to make changes in its product and specifications at any time and without notice. The Amkor name and logo are registered trademarks of Amkor Technology, Inc. All other trademarks mentioned are property of their respective companies. © 2021 Amkor Technology, Incorporated. All Rights Reserved. DS618D-EN Rev Date: 02/21

